

33390

Class B Serial Transceiver

The 33390 is a serial transceiver designed to provide bi-directional half-duplex communication meeting the automotive SAE Standard J-1850 Class B Data Communication Network Interface specification. It is designed to interface directly to on-board vehicle microcontrollers and serves to transmit and receive data on a single-wire bus at data rates of 10.4 kbps using Variable Pulse Width Modulation (VPWM). The 33390 operates directly from a vehicle's 12 V battery system and functions in a logic fashion as an I/O interface between the microcontroller's 5.0 V CMOS logic level swings and the required 0 V to 7.0 V wavelshaped signal swings of the bus. The bus output driver is short circuit current limited.

Features

- Designed for SAE J-1850 Class B Data Rates
- Full Operational Bus Dynamics Over a Supply Voltage of 9.0 to 16 V
- Ambient Operating Temperature of -40°C to 125°C
- Interfaces Directly to Standard 5.0 V CMOS Microcontroller
- BUS Pin Protected Against Shorts to Battery and Ground
- Thermal Shutdown with Hysteresis
- Voltage Waveshaping of Bus Output Driver
- 40 V Max V_{BAT} Capability

J-1850 SERIAL TRANSCEIVER

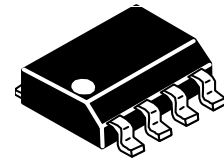

**D SUFFIX
PLASTIC PACKAGE
CASE 751
(8-LEAD SOICN)**

ORDERING INFORMATION

Device	Temperature Range (T_A)	Package
MC33390D/DR2	-40 to 125°C	8 SOICN

33390 Simplified Application Diagram

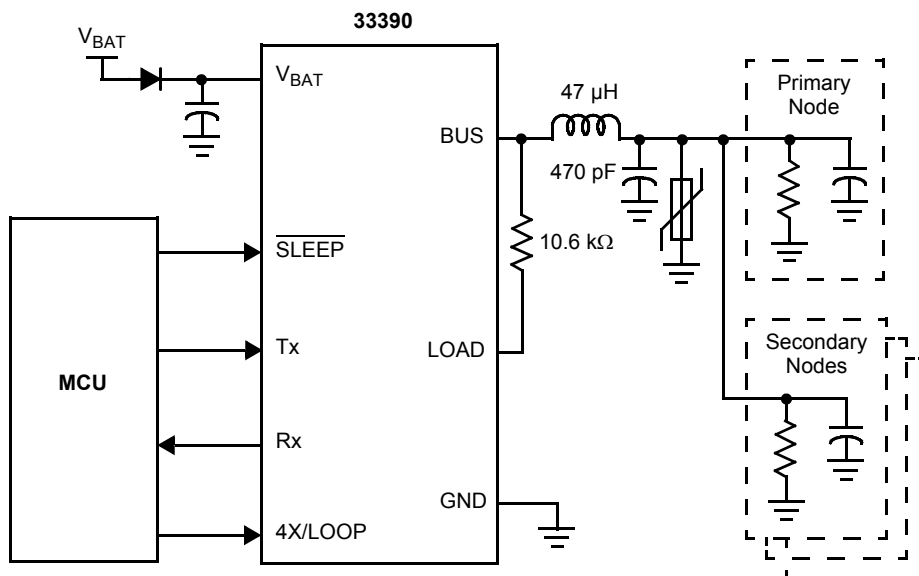

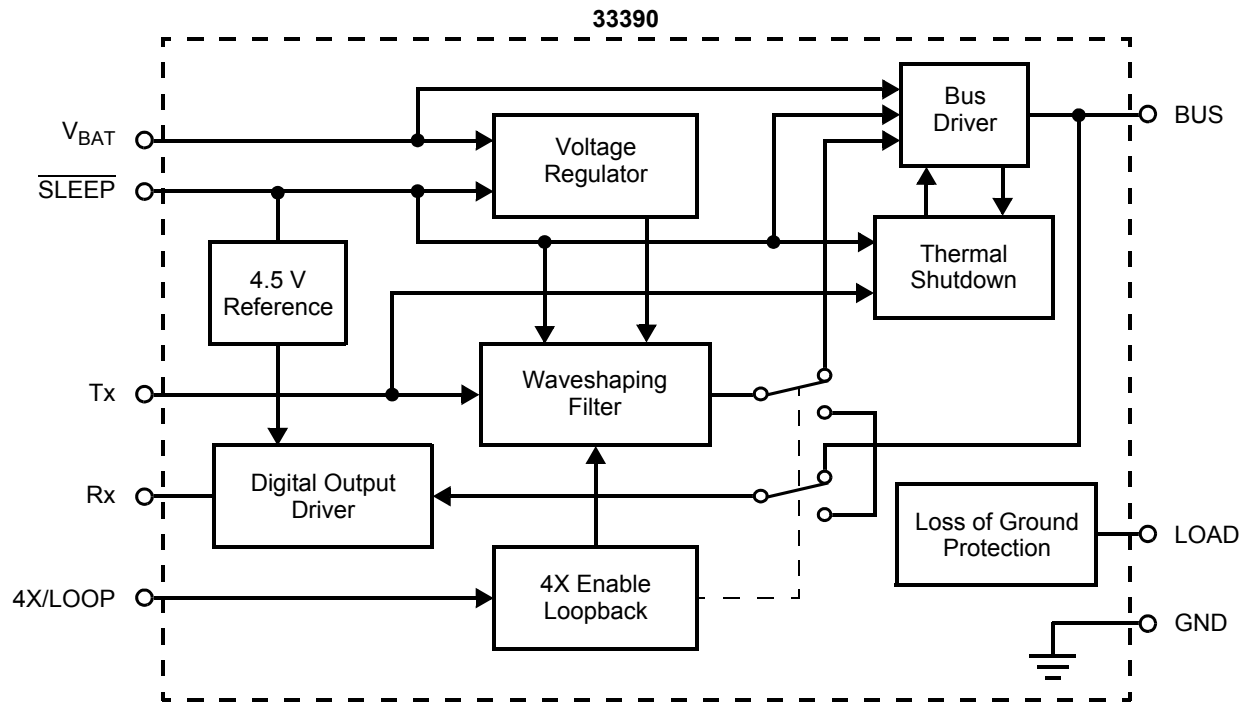

Note This device contains approximately 400 active transistors and 250 gates.

Figure 1. 33390 Simplified Block Diagram

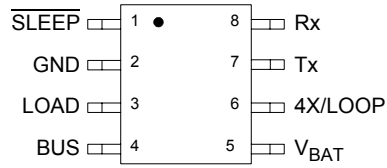

PIN FUNCTION DESCRIPTION

Pin	Pin Name	Description
1	$\overline{\text{SLEEP}}$	Enables the transceiver when Logic 1 and disables the transceiver when Logic 0.
2	GND	Device ground pin.
3	LOAD	Accommodates an external pull-down resistor to ground to provide loss of ground protection.
4	BUS	Waveshaped SAE Standard J-1850 Class B transmitter output and receiver input.
5	V_{BAT}	Provides device operating input power.
6	4X/LOOP	Tristate input mode control; Logic 0 = normal waveshaping, Logic 1 = waveshaping disabled for 4X transmitting, high impedance = loopback mode.
7	Tx	Serial data input (DI) from the microcontroller to be transmitted onto Bus.
8	Rx	Bus received serial data output (DO) sent to the microcontroller.

MAXIMUM RATINGS

All voltages are with respect to ground unless otherwise noted.

Rating	Symbol	Value	Unit
V _{BAT} DC Supply Voltage (Note 1)	V _{BAT}	-0.3 to 40	V
Input I/O Terminals (Note 2)	V _{I/O(CPU)}	-0.3 to 7.0	V
BUS and LOAD Outputs	V _{BUS}	-2.0 to 16	V
ESD Voltage			V
Human Body Model (Note 3)	V _{ESD1}	±2000	
Machine Model (Note 4)	V _{ESD2}	±200	
Storage Temperature	T _{STG}	-65 to 150	°C
Operating Ambient Temperature	T _A	-40 to 125	°C
Operating Junction Temperature	T _J	-40 to 150	°C
Soldering Temperature (for 10 seconds)	T _{SOLDER}	260	°C
Thermal Resistance (Junction-to-Ambient)	R _{θJ-A}	180	°C/W

Notes

1. An external series diode must be used to provide reverse battery protection of the device.
2. SLEEP, TX, RX, and 4X/LOOP are normally connected to a microcontroller.
3. ESD1 testing is performed in accordance with the Human Body Model (C_{ZAP}=100 pF, R_{ZAP}=1500 Ω).
4. ESD2 testing is performed in accordance with the Machine Model (C_{ZAP}=200 pF, R_{ZAP}=0 Ω).

STATIC ELECTRICAL CHARACTERISTICS

Characteristics noted under conditions of $7.0\text{ V} \leq V_{\text{BAT}} \leq 16\text{ V}$, $-40^\circ\text{C} \leq T_{\text{A}} \leq 125^\circ\text{C}$, $\overline{\text{SLEEP}} = 5.0\text{ V}$ unless otherwise noted. Typical values reflect the parameter's approximate midpoint average value with $V_{\text{BAT}} = 13\text{ V}$, $T_{\text{A}} = 25^\circ\text{C}$. All positive currents are into the pin. All negative currents are out of the pin.

Characteristic	Symbol	Min	Typ	Max	Unit
----------------	--------	-----	-----	-----	------

POWER CONSUMPTION

Operational Battery Current (RMS with Tx = 7.812 kHz Square Wave) BUS Load = 1380 Ω to GND, 3.6 nF to GND BUS Load = 257 Ω to GND, 20.2 nF to GND	$I_{\text{BAT(OP1)}}$ $I_{\text{BAT(OP2)}}$	– –	3.0 22.4	11.5 32	mA
Battery Bus Low Input Current After $\overline{\text{SLEEP}}$ Toggle Low to High; Prior to Tx Toggling After Tx Toggle High to Low	$I_{\text{BAT(BUS L1)}}$ $I_{\text{BAT(BUS L2)}}$	– –	1.1 6.4	3.0 8.5	mA
Sleep State Battery Current $V_{\overline{\text{SLEEP}}} = 0\text{ V}$	$I_{\text{BAT}(\overline{\text{SLEEP}})}$	–	38.2	65	μA

BUS

BUS Input Receiver Threshold (Note 5) Threshold High (Bus Increasing until $R_x \geq 3.0\text{ V}$) Threshold Low (Bus Decreasing until $R_x \leq 3.0\text{ V}$) Threshold in Sleep State ($\overline{\text{SLEEP}} = 0\text{ V}$) Hysteresis ($V_{\text{BUS(IH)}} - V_{\text{BUS(IL)}}$, $\overline{\text{SLEEP}} = 0\text{ V}$)	$V_{\text{BUS(IH)}}$ $V_{\text{BUS(IL)}}$ $V_{\text{BUS(TH(SLEEP))}}$ $V_{\text{BUS(HYST)}}$	4.25 – 2.4 0.1	3.9 3.7 3.0 0.2	– 3.5 3.4 0.6	V
BUS-Out Voltage ($257\ \Omega \leq R_{\text{BUS(L)}} \leq 1380\ \Omega$) $8.2\text{ V} \leq V_{\text{BAT}} \leq 16\text{ V}$, Tx = 5.0 V $4.25\text{ V} \leq V_{\text{BAT}} \leq 8.2\text{ V}$, Tx = 5.0 V Tx = 0 V	$V_{\text{BUS(OUT1)}}$ $V_{\text{BUS(OUT2)}}$ $V_{\text{BUS(OUT3)}}$	6.25 $V_{\text{BAT}} - 1.6$ –	6.9 – 0.27	8.0 V_{BAT} 0.7	V
BUS Short Circuit Output Current Tx = 5.0 V, $-2.0\text{ V} \leq V_{\text{BUS}} \leq 4.8\text{ V}$	$I_{\text{BUS(SHORT)}}$	60	129	170	mA
BUS Leakage Current $-2.0\text{ V} \leq V_{\text{BUS}} \leq 0\text{ V}$ $0\text{ V} \leq V_{\text{BUS}} \leq V_{\text{BAT}}$	$I_{\text{BUS(LEAK1)}}$ $I_{\text{BUS(LEAK2)}}$	-500 –	-55 189	– 500	μA
BUS Thermal Shutdown (Note 6) (Tx = 5.0 V, $I_{\text{BUS}} = -0.1\text{ mA}$) Increase Temperature until $V_{\text{BUS}} \leq 2.5\text{ V}$	$T_{\text{BUS(LIM)}}$	150	170	190	$^\circ\text{C}$
BUS Thermal Shutdown Hysteresis (Note 7) $T_{\text{BUS(LIM)}} - T_{\text{BUS(REEN)}}$	$T_{\text{BUS(LIMHYS)}}$	10	12	15	$^\circ\text{C}$
BUS and LOAD Current with Loss of V_{BAT} or GND ($I_{\text{BAT}} = 0\ \mu\text{A}$) (see Figure 2) $-18\text{ V} \leq V_{\text{BUS}} \leq 9.0\text{ V}$ $-18\text{ V} \leq V_{\text{LOAD}} \leq 9.0\text{ V}$	$I_{\text{BUS(LOSS)}}$ $I_{\text{LOAD(LOSS)}}$	– –	0.00 0.00	0.1 0.1	mA

Notes

- Typical threshold value is the approximate actual occurring switch point value with $V_{\text{BAT}} = 13\text{ V}$, $T_{\text{A}} = 25^\circ\text{C}$.
- Device characterized but not production tested for thermal shutdown.
- Device characterized but not production tested for thermal shutdown hysteresis.

STATIC ELECTRICAL CHARACTERISTICS (continued)

Characteristics noted under conditions of $7.0\text{ V} \leq V_{\text{BAT}} \leq 16\text{ V}$, $-40^\circ\text{C} \leq T_{\text{A}} \leq 125^\circ\text{C}$, $\overline{\text{SLEEP}} = 5.0\text{ V}$ unless otherwise noted. Typical values reflect the parameter's approximate midpoint average value with $V_{\text{BAT}} = 13\text{ V}$, $T_{\text{A}} = 25^\circ\text{C}$. All positive currents are into the pin. All negative currents are out of the pin.

Characteristic	Symbol	Min	Typ	Max	Unit
----------------	--------	-----	-----	-----	------

BUS (continued)

LOAD Output $I_{\text{L}} = 6.0\text{ mA}$	L_{ON}	–	0.07	0.2	V
Unpowered LOAD Output $V_{\text{BAT}} = 0\text{ V}$, $I_{\text{L}} = 6.0\text{ mA}$	L_{DIO}	0.3	0.56	0.9	V

Tx

Tx Input Voltage Tx Input Logic Low Level Tx Input Logic High Level	$V_{\text{Tx(IL)}}$ $V_{\text{Tx(IH)}}$	– 3.5	– –	0.8 –	V
Tx Input Current $V_{\text{Tx}} = 5.0\text{ V}$ $V_{\text{Tx}} = 0\text{ V}$	$I_{\text{Tx(IH)}}$ $I_{\text{Tx(IL)}}$	50 -2.0	106 0.23	200 2.0	μA

LOOP

4X/LOOP Input Current $V_{4\text{X}/\text{LOOP}} = 0\text{ V}$ (Normal Mode) $V_{4\text{X}/\text{LOOP}} = 5.0\text{ V}$ (4X Mode)	$I_{4\text{X}/\text{LOOP(IL)}}$ $I_{4\text{X}/\text{LOOP(IH)}}$	-200 -200	-60 110	200 200	μA
4X/LOOP Input Threshold (Tx = 4096 Hz Square Wave) Normal Mode to Loopback Mode Loopback Mode to 4X Mode	$V_{4\text{X}/\text{LOOP(IL)}}$ $V_{4\text{X}/\text{LOOP(IH)}}$	1.1 3.2	1.31 3.43	1.5 3.6	V

Rx

Rx Output Voltage Low $V_{\text{BUS}} = 0\text{ V}$, $I_{\text{RX}} = 1.6\text{ mA}$	$V_{\text{Rx(LOW)}}$	0.01	0.18	0.4	V
Rx Output Voltage High $V_{\text{BUS}} = 7.0\text{ V}$, $I_{\text{RX}} = -200\text{ }\mu\text{A}$	$V_{\text{Rx(HIGH)}}$	4.25	4.58	4.75	V
Rx Output Current $V_{\text{Rx}} = \text{High}$; Short Circuit Protection Limits	I_{RX}	2.0	3.67	8.0	mA

SLEEP

SLEEP Input Current $V_{\text{SLEEP}} = 0\text{ V}$ $V_{\text{SLEEP}} = 5.0\text{ V}$	$I_{\text{SLEEP(IL)}}$ $I_{\text{SLEEP(IH)}}$	– 1.0	-0.23 6.21	-2.0 20	μA
---	--	----------	---------------	------------	---------------

DYNAMIC ELECTRICAL CHARACTERISTICS

Characteristics noted under conditions of $7.0\text{ V} \leq V_{\text{BAT}} \leq 16\text{ V}$, $-40^\circ\text{C} \leq T_{\text{A}} \leq 125^\circ\text{C}$, $\overline{\text{SLEEP}} = 5.0\text{ V}$ unless otherwise noted. Typical values reflect the parameter's approximate midpoint average value with $V_{\text{BAT}} = 13\text{ V}$, $T_{\text{A}} = 25^\circ\text{C}$. All positive currents are into the pin. All negative currents are out of the pin.

Characteristic	Symbol	Min	Typ	Max	Unit
----------------	--------	-----	-----	-----	------

BUS

BUS Voltage Rise Time (Note 8) ($9.0\text{ V} \leq V_{\text{BAT}} \leq 16\text{ V}$, Tx = 7.812 kHz Square Wave) (see Figure 3) BUS Load = 3,300 pF and 1.38 k Ω to GND BUS Load = 16,500 pF and 300 Ω to GND	$t_{\text{rise}}(\text{BUS})$	9.0 9.0	11.15 11.86	15 15	μs
BUS Voltage Fall Time (Note 8) ($9.0\text{ V} \leq V_{\text{BAT}} \leq 16\text{ V}$, Tx = 7.812 kHz Square Wave) (see Figure 3) BUS Load = 3,300 pF and 1.38 k Ω to GND BUS Load = 16,500 pF and 300 Ω to GND	$t_{\text{fall}}(\text{BUS})$	9.0 9.0	10.50 11.17	15 15	μs
Pulse Width Distortion Time ($9.0\text{ V} \leq V_{\text{BAT}} \leq 16\text{ V}$, Tx = 7.812 kHz Square Wave) (see Figure 4) BUS Load = 3,300 pF and 1.38 k Ω to GND	$t_{\text{pwd}}(\text{BUS})$	35	62	93	μs
Propagation Delay Tx Threshold to Rx Threshold	$t_{\text{pd}}(\text{BUS})$	–	17.7	25	μs

Tx

Tx to BUS Delay Time (Tx = 2.5 V to $V_{\text{BUS}} = 3.875\text{ V}$) (see Figure 5) 4X Mode Normal Mode	t_{TxDelay}	– 13	2.6 17.3	4.0 24	μs
$\overline{\text{SLEEP}}$ to Tx Setup Time (see Figure 5)	$t_{\text{SLEEPTxSU}}$	80	40	–	μs

Rx

Rx Output Delay Time (Tx = 2.5 V to $V_{\text{BUS}} = 3.875\text{ V}$) (see Figure 6) Low-to-Output High High-to-Output Low	$t_{\text{RxDelay/L-H}}$ $t_{\text{RxDelay/H-L}}$	– –	0.11 0.38	2.0 2.0	μs
Rx Output Transition Time ($C_{\text{RX}} = 50\text{ pF}$ to GND, 10% and 90% Points) (see Figure 7) Low-to-Output High High-to-Output Low	$t_{\text{RxTrans/L-H}}$ $t_{\text{RxTrans/H-L}}$	– –	0.34 0.08	1.0 1.0	μs
Rx Output Transition Time (Note 9) ($C_{\text{RX}} = 50\text{ pF}$ to GND, $\overline{\text{SLEEP}} = 0\text{ V}$, 10% and 90% Points) (see Figure 7) Low-to-Output High High-to-Output Low	$t_{\text{RxTrans/L-H}}$ $t_{\text{RxTrans/H-L}}$	– –	0.32 0.08	5.0 5.0	μs

Notes

- Typical is the parameter's approximate average value with $V_{\text{BAT}} = 13\text{ V}$, $T_{\text{A}} = 25^\circ\text{C}$.
- Rx Output Transition Time from a sleep state.

Electrical Performance Curves

Test Figures

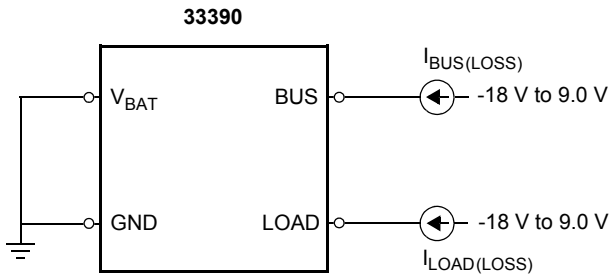

Figure 2. Loss of Ground or V_{BAT} Test Circuit

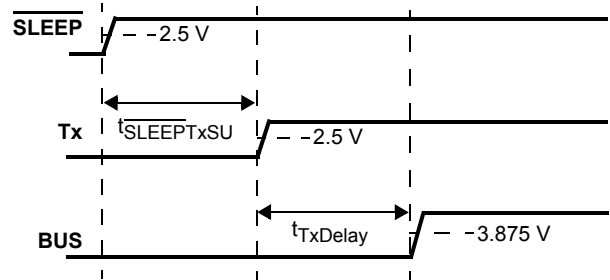

Figure 5. $\overline{\text{SLEEP}}$ to Tx Delay Times

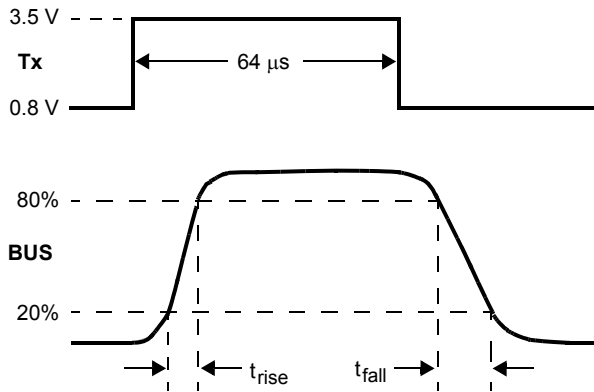

Figure 3. BUS Rise and Fall Times

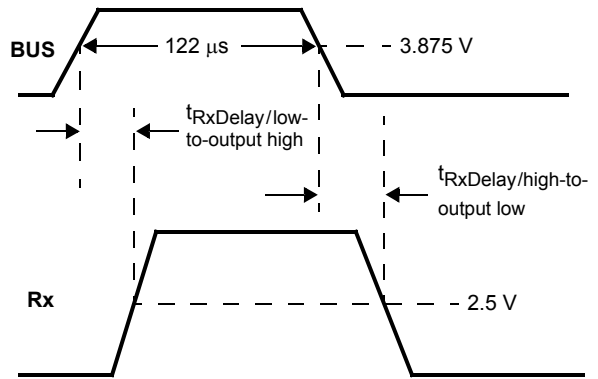

Figure 6. BUS-to-Rx Delay Time

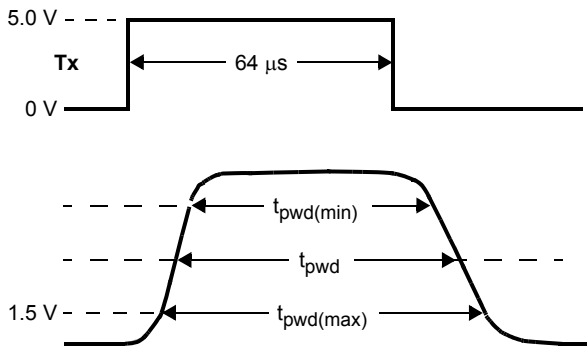

Figure 4. Pulse Width Distortion

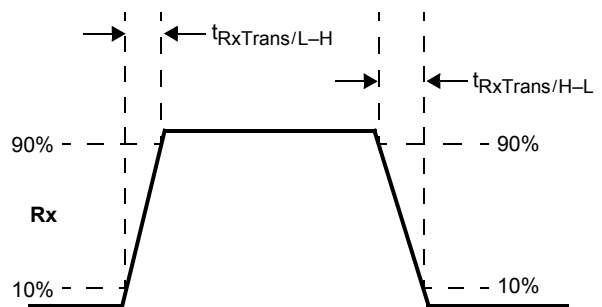

Figure 7. Rx Rise and Fall Time

SYSTEM/APPLICATION INFORMATION

INTRODUCTION

The 33390 is a serial transceiver device designed to meet the SAE Standard J-1850 Class B performance for bi-directional half-duplex communication. The device is packaged in an economical surface-mount SOIC plastic package. An internal block diagram of the device is shown in Figure 1.

The 33390 derives its robustness to temperature and voltage extremes from being built on a SMARTMOS process, incorporating CMOS logic, bipolar/MOS analog circuitry, and

DMOS power FETs. Though the 33390 was principally designed for automotive applications requiring SAE J-1850 Class B standards, it is suited for other serial communication applications. It is parametrically specified over an ambient temperature range of $-40^{\circ}\text{C} \leq T_A \leq 125^{\circ}\text{C}$ and $7.0\text{ V} \leq V_{\text{BAT}} \leq 16\text{ V}$ supply. The economical 8-pin SOICN surface mount plastic package makes the device a cost-effective solution.

FUNCTIONAL DESCRIPTION

Input Power (V_{BAT} Pin)

This is the only required input power source necessary to operate the 33390. The internal voltage reference of the 33390 will remain fully operational with a minimum of 9.0 V on this pin. Bus transmissions can continue with battery voltages down to 5.0 V. The bus output voltage will follow the battery voltage down and, in doing so, track approximately 1.6 V below the battery voltage. The device will continue to receive and transmit bus data to the microcontroller with battery voltages as low as 4.25 V. The pin can withstand voltages from -0.3 V to 40 V. If reverse battery protection is required, an appropriate diode must be placed in series with this pin to protect the IC.

Sleep Input ($\overline{\text{SLEEP}}$ Pin)

This input is used to enable and disable the Class B transmitter. The Class B receiver is always enabled so long as adequate V_{BAT} pin voltage is applied. When the $\overline{\text{SLEEP}}$ pin voltage is 5.0 V, the Class B transmitter is enabled. If this input is 0 V, the Class B transmitter will be disabled and less than 65 μA of current will be drawn by the V_{BAT} pin. The pin also provides a 5.0 V reference, internal to the device, used to establish the Rx output level and slew rate times.

Class B Functional Description

The transmitter provides an analog waveshaped 0 V to 7.0 V waveform on the BUS output. It also receives waveforms and transmits a digital level signal back to a logic IC. The transmitter can drive up to 32 secondary Class B transceivers (see Figures 8 and 9). These secondary nodes may be at ground potentials that are $\pm 2.0\text{ V}$ relative to the control assembly. Waveshaping will only be maintained during 2 of the 4 corners when the 0 to $\pm 2.0\text{ V}$ ground potential difference condition exists. The 33390 is a secondary node on the Class B bus. Each secondary transceiver has a $470 \pm 10\%$ pF capacitor on its output for EMI suppression purposes, as well as a $10.6\text{ k}\Omega \pm 5\%$ pull-down resistor to ground. The primary node has a $3300 \pm 10\%$ pF capacitor on its output for EMI suppression, as well as a $1.5\text{ k}\Omega \pm 5\%$ pull-down resistor to ground. With more than 26 nodes, there is no primary node (see Figure 10). All nodes will have a $470 \pm 10\%$ pF capacitor and a $10.6\text{ k}\Omega \pm 5\%$ pull-down resistor. No matter how many secondary nodes are

on the Class B bus, the RC time constant of the Class B bus is maintained at approximately 5.0 μs . The minimum and maximum capacitance and resistance on the Class B bus is given by the expressions shown in Table 1, page 10.

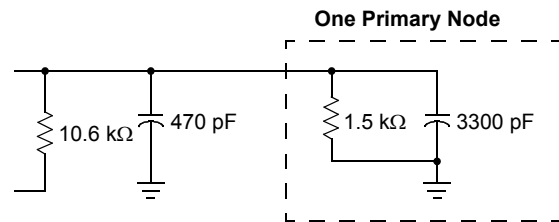

Figure 8. Minimum Bus Load

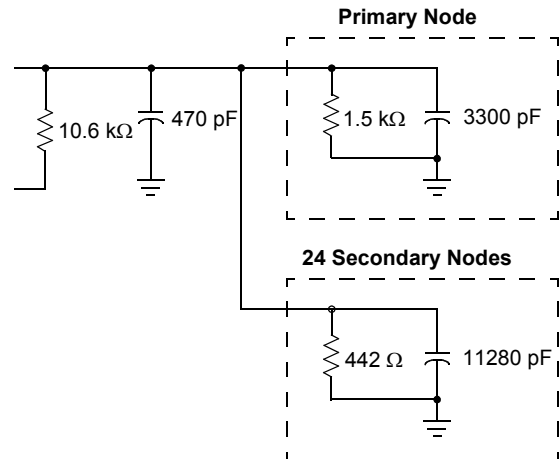

Figure 9. Maximum Number of Nodes

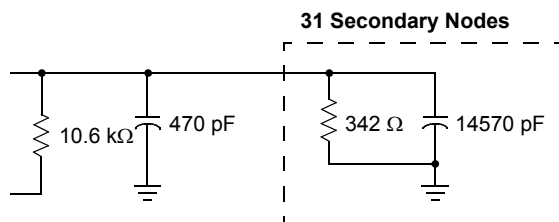

Figure 10. Maximum Bus Load

Table 1. Class B Bus Capacitance and Resistance Expressions

Level	Capacitance	Resistance to Ground
Minimum	$(3.3 \times 0.9) + (0.47 \times 0.9) = 3.39 \text{ nF}$	$(1.5 \times 0.95) \parallel (10.6 \times 0.95) / 25 = 314 \ \Omega$
Maximum	$(3.3 \times 1.1) + 25(0.47 \times 1.1) = 16.55 \text{ nF}$	$(1.5 \times 1.05) \parallel (10.6 \times 1.05) = 1.38 \text{ k}\Omega$

APPLICATIONS

Class B Module Inputs

Transmitter Data from the MCU (Tx)

The Tx input is a push-pull (N-channel/P-channel FETs) buffer with hysteresis for noise immunity purposes. This pin is a 5.0 V CMOS logic level input from the MCU following a true logic protocol. A logic [0] input drives the BUS output to 0 V (via the external pull-down resistor to ground on each node), while a logic [1] input produces a high voltage at the BUS output. A logic [0] input level is guaranteed when the Tx input pin is open-circuited by virtue of an internal 40 k Ω pull-down resistor. No external resistor is required for its operation.

Waveshaping and 4X/Loop

This input is a tristateable input: 0 V = normal waveshaping, 5.0 V = waveshaping is disabled for 4X transmitting, and high impedance = loopback mode of operation. This is a logic level input used to select whether waveshaping for the Class B output is enabled or disabled. A logic [0] enables waveshaping, while a logic [1] disables waveshaping. In the 4X mode, the BUS output rise time is less than 2.0 μs and the fall time is less than 5.0 μs (owing to the external RC pull-down to ground). In the loopback condition, the Tx signal is fed back to the Rx output *after* waveshaping *without* being transmitted onto the BUS. This mode of operation is useful for system diagnostic purposes.

Class B Module Outputs

Transceiver Output (BUS)

This is the output driver stage that sources current to the bus. Its output follows the waveshaped waveform input. Its output voltage is limited to 6.25 V to 8.0 V under normal battery level conditions. The limited level is controlled by an internal regulator/clamp circuit. Once the battery voltage drops below 9.0 V, the regulator/clamp circuit saturates, causing the bus voltage to track the battery voltage. A 1.5 k $\Omega \pm 5\%$ external resistor (as well as any 10.6 k Ω pull-down resistors of any secondary nodes) sinks the current to discharge the capacitors during high-to-low transitions. This sourcing output is short circuit-protected (60 mA to 170 mA) against a short to -2.0 V and sinks less than 1.0 mA when shorted to V_{BAT} . If a short occurs, the overtemperature shutdown circuit protects the source driver of the device. In the event battery power is lost to the assembly, the bus transmitter's output stage will be disabled and the leakage current from the BUS output will not source or sink more than 100 μA of current. The transceiver will operate

with a remote ground offset of $\pm 2.0 \text{ V}$, but the lower corners of transmission will *not* be rounded during this condition.

Receiver Output to the Microcontroller (Rx)

This is a 5.0 V CMOS compatible push-pull output used to send received data to the microcontroller. It does not require an external pull-up resistor to be used. The receiver is always enabled and draws less than 65 μA of current from V_{BAT} . The receive threshold is dependent on the state of the $\overline{\text{SLEEP}}$ pin. The receiver circuitry is able to operate with V_{BAT} voltages as low as 4.25 V and still remains capable of "waking up" the 33390 when remote Class B activity is detected.

When the $\overline{\text{SLEEP}}$ pin is 0 V and message activity occurs on the bus, the receiver passes the bus message through to the microcontroller. The 33390 does not automatically "wake up" from a sleep state when bus activity occurs: the microcontroller must tell it to do so.

In the Static Electrical Characteristics table, the maximum voltage for Rx is specified as 4.75 V over an operating range of -40°C to 125°C temperature and 7.0 V to 16 V V_{BAT} . This maximum Rx voltage is compatible with the minimum V_{DD} voltage of microcontrollers to prevent the 33390 from sourcing current to the microcontroller's output.

Switched Ground Output (LOAD)

Normally this output is a saturated switch to ground, which pulls down the external resistor between the BUS and LOAD outputs. In the event ground is lost to the assembly, the LOAD output will bias itself "off" and will not leak more than 100 μA of current out of this pin.

Overtemperature Shutdown

If the BUS output becomes shorted to ground for any duration, an overtemperature shutdown circuit "latches off" the output source transistor whenever the die temperature exceeds 150°C to 190°C. The output transistor remains latched off until the Tx input is toggled from a logic [0] to a logic [1]. The rising edge provides the clearing function, provided the locally sensed temperature is 10°C to 15°C below the latch-off temperature trip temperature.

Waveshaping

Waveshaping is incorporated into the 33390 to minimize radiated EMI emissions.

Receiver Protocol

The Class B communication scheme uses a variable pulse width (VPW) protocol. The microcontroller provides the VPW decoding function. Once the receiver detects a transition on Rx, it starts an internal counter. The initial “start of frame” bit is a logic [1] and lasts 200 μ s. For subsequent bits, if there is a bus transition before 96 μ s, one logic state is inferred. If there is a bus transition after 96 μ s, the other logic state is inferred. The “end of data” bit is a logic [0] and lasts 200 μ s. If there is no activity on the bus for 280 μ s to 320 μ s following a broadcast message, multiple unit nodes may arbitrate for control of the next message. During an arbitration, after the “start of frame” bit has been transmitted, the secondary node transmitting the most consecutive logic [0] bits will be granted sole transmission access to the bus for that message.

Loss of Assembly Ground Connection

The definition of a loss of assembly ground condition at the device level is that all pins of the 33390, with the exception of BUS and LOAD, see a very low impedance to V_{BAT} .

The LOAD pin of the device has an internal transistor switch connected to it that is normally saturated to ground. This pulls the LOAD-side of the external resistor (tied from BUS to LOAD)

to ground under normal conditions. The LOAD pin switch is essentially that of an “upside down” FET, which is normally biased “on” so long as module ground is present and biased “off” when loss-of-ground occurs. When a loss of assembly ground occurs, the load transistor switch is self-biased “off”, allowing no more than 100 μ A of leakage current to flow in the LOAD pin. During such a loss of assembly ground condition, the BUS and LOAD pins exhibit a high impedance to V_{BAT} ; all other pins will exhibit a low impedance to V_{BAT} . During this condition the BUS pin is prevented from sourcing any current or loading the bus, which would cause a corruption of any data being transmitted on the bus. While a particular assembly is experiencing a loss of ground, all other assembly nodes are permitted to function normally. It should be noted that with other nodes existing on the bus, the bus will always have some minimum/maximum impedance to ground as shown in Table 1, page 10.

Loss of Assembly Battery Connection

The definition of a loss of assembly battery condition at the device level is that the V_{BAT} pin of the 33390 sees an infinite impedance to V_{BAT} , but there is some undefined impedance between these pins and ground.

PACKAGE DIMENSIONS

D SUFFIX
 (8-LEAD SOIC NARROW BODY)
 PLASTIC PACKAGE
 CASE 751-06
 ISSUE T

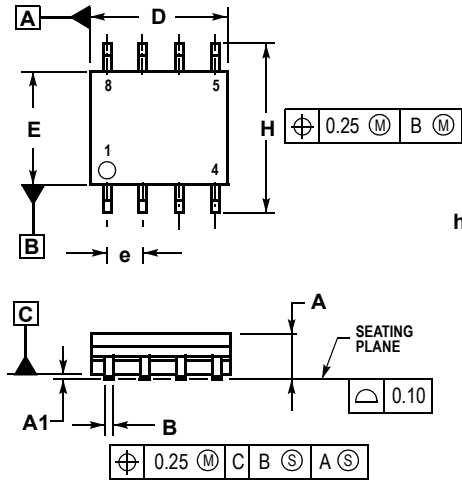

NOTES:

1. DIMENSIONING AND TOLERANCING PER ASME Y14.5M, 1994.
2. DIMENSIONS ARE IN MILLIMETERS.
3. DIMENSION D AND E DO NOT INCLUDE MOLD PROTRUSION.
4. MAXIMUM MOLD PROTRUSION 0.15 PER SIDE.
5. DIMENSION B DOES NOT INCLUDE DAMBAR PROTRUSION. ALLOWABLE DAMBAR PROTRUSION SHALL BE 0.127 TOTAL IN EXCESS OF THE B DIMENSION AT MAXIMUM MATERIAL CONDITION.

DIM	MILLIMETERS	
	MIN	MAX
A	1.35	1.75
A1	0.10	0.25
B	0.35	0.49
C	0.19	0.25
D	4.80	5.00
E	3.80	4.00
e	1.27 BSC	
H	5.80	6.20
h	0.25	0.50
L	0.40	1.25
θ	0°	7°

NOTES

NOTES

NOTES

Information in this document is provided solely to enable system and software implementers to use Motorola products. There are no express or implied copyright licenses granted hereunder to design or fabricate any integrated circuits or integrated circuits based on the information in this document.

Motorola reserves the right to make changes without further notice to any products herein. Motorola makes no warranty, representation or guarantee regarding the suitability of its products for any particular purpose, nor does Motorola assume any liability arising out of the application or use of any product or circuit, and specifically disclaims any and all liability, including without limitation consequential or incidental damages. "Typical" parameters which may be provided in Motorola data sheets and/or specifications can and do vary in different applications and actual performance may vary over time. All operating parameters, including "Typicals" must be validated for each customer application by customer's technical experts. Motorola does not convey any license under its patent rights nor the rights of others. Motorola products are not designed, intended, or authorized for use as components in systems intended for surgical implant into the body, or other applications intended to support or sustain life, or for any other application in which the failure of the Motorola product could create a situation where personal injury or death may occur. Should Buyer purchase or use Motorola products for any such unintended or unauthorized application, Buyer shall indemnify and hold Motorola and its officers, employees, subsidiaries, affiliates, and distributors harmless against all claims, costs, damages, and expenses, and reasonable attorney fees arising out of, directly or indirectly, any claim of personal injury or death associated with such unintended or unauthorized use, even if such claim alleges that Motorola was negligent regarding the design or manufacture of the part.

MOTOROLA and the Stylized M Logo are registered in the US Patent and Trademark Office. All other product or service names are the property of their respective owners.

© Motorola, Inc. 2003

HOW TO REACH US:

USA/EUROPE/LOCATIONS NOT LISTED:

Motorola Literature Distribution
P.O. Box 5405, Denver, Colorado 80217
1-800-521-6274 or 480-768-2130

JAPAN: Motorola Japan Ltd.; SPS, Technical Information Center
3-20-1 Minami-Azabu, Minato-ku, Tokyo 106-8573, Japan
81-3-3440-3569

ASIA/PACIFIC: Motorola Semiconductors H.K. Ltd.; Silicon Harbour Centre
2 Dai King Street, Tai Po Industrial Estate, Tai Po, N.T., Hong Kong
852-26668334

HOME PAGE: <http://motorola.com/semiconductors>



MOTOROLA

SUNSTAR 商斯达实业集团是集研发、生产、工程、销售、代理经销、技术咨询、信息服务等为一体的高科技企业，是专业高科技电子产品生产厂家，是具有 10 多年历史的专业电子元器件供应商，是中国最早和最大的仓储式连锁规模经营大型综合电子零部件代理分销商之一，是一家专业代理和分销世界各大品牌 IC 芯片和电子元器件的连锁经营综合性国际公司，专业经营进口、国产名厂名牌电子元件，型号、种类齐全。在香港、北京、深圳、上海、西安、成都等全国主要电子市场设有直属分公司和产品展示展销窗口门市部专卖店及代理分销商，已在全国范围内建成强大统一的供货和代理分销网络。我们专业代理经销、开发生产电子元器件、集成电路、传感器、微波光电元器件、工控机/DOC/DOM 电子盘、专用电路、单片机开发、MCU/DSP/ARM/FPGA 软件硬件、二极管、三极管、模块等，是您可靠的一站式现货配套供应商、方案提供商、部件功能模块开发配套商。商斯达实业公司拥有庞大的资料库，有数位毕业于著名高校——有中国电子工业摇篮之称的西安电子科技大学（西军电）并长期从事国防尖端科技研究的高级工程师为您精挑细选、量身订做各种高科技电子元器件，并解决各种技术问题。

更多产品请看本公司产品专用销售网站：

商斯达中国传感器科技信息网：<http://www.sensor-ic.com/>

商斯达工控安防网：<http://www.pc-ps.net/>

商斯达电子元器件网：<http://www.sunstare.com/>

商斯达微波光电产品网：[HTTP://www.rfoe.net/](http://www.rfoe.net/)

商斯达消费电子产品网：<http://www.icasic.com/>

商斯达实业科技产品网：<http://www.sunstars.cn/>

传感器销售热线：

地址：深圳市福田区福华路福庆街鸿图大厦 1602 室

电话：0755-83370250 83376489 83376549 83607652 83370251 82500323

传真：0755-83376182 (0) 13902971329 MSN: SUNS8888@hotmail.com

邮编：518033 E-mail:szss20@163.com QQ: 195847376

深圳赛格展销部：深圳华强北路赛格电子市场 2583 号 电话：0755-83665529 25059422

技术支持：0755-83394033 13501568376

欢迎索取免费详细资料、设计指南和光盘；产品凡多，未能尽录，欢迎来电查询。

北京分公司：北京海淀区知春路 132 号中发电子大厦 3097 号

TEL: 010-81159046 82615020 13501189838 FAX: 010-62543996

上海分公司：上海市北京东路 668 号上海赛格电子市场 2B35 号

TEL: 021-28311762 56703037 13701955389 FAX: 021-56703037

西安分公司：西安高新开发区 20 所(中国电子科技集团导航技术研究所)

西安劳动南路 88 号电子商城二楼 D23 号

TEL: 029-81022619 13072977981 FAX:029-88789382